



Roof Cable Management System

Suitable for UFC 200 and UFC 500
equipped with Status Light Roof.

**Installation and Service
Instruction**

www.deltaww.com



Table of content

| | |
|--|-----------|
| 1 Document management..... | 5 |
| 1.1 Change history | 5 |
| 2 Safety | 6 |
| 2.1 General safety information..... | 6 |
| 2.2 Safety instructions..... | 7 |
| 3 About this manual | 9 |
| 3.1 Validity | 9 |
| 3.1.1 Hardware version | 9 |
| 3.2 Target groups | 9 |
| 3.3 Conventions | 10 |
| 3.3.1 Instructions in the text | 10 |
| 4 Product description | 11 |
| 5 Packing and delivery | 14 |
| 5.1.1 Package contents | 14 |
| 5.1.2 Unpacking | 15 |
| 6 Preparation of the charger and space..... | 17 |
| 7 CMS set material preparation | 19 |
| 7.1 Construction elements | 19 |
| 7.2 Arm and clamps | 20 |
| 8 CMS Assembly instruction | 23 |
| 8.1 Requirements and restrictions: | 23 |
| 8.2 Tools preparation | 23 |
| 8.2.1 First assembly..... | 23 |
| 8.2.2 Service of CMS..... | 23 |
| 8.2.3 Service parts for crane/forklift usage | 24 |
| 8.3 Installation instruction | 24 |
| 8.3.1 Structure assembly..... | 24 |
| 9 Verification of correct installation..... | 37 |
| 9.1.1 Example of incorrect assembly | 38 |
| 10 Maintenance inspections..... | 40 |
| 10.1 General information..... | 40 |
| 10.2 Chain inspection..... | 40 |

| | | |
|-----------|--|-----------|
| 10.3 | Gasspring Inspection | 40 |
| 10.4 | Rotary joint inspection | 40 |
| 10.5 | General CMS inspection | 40 |
| 10.6 | Clamp inspection | 41 |
| 10.7 | Service card | 41 |
| 10.8 | Contraindications | 41 |
| 11 | Gasspring replacement | 42 |
| 11.1 | Requirements and restrictions: | 42 |
| 11.2 | Tools preparation | 42 |
| 11.2.1 | Gasspring replacement | 42 |
| 12 | Restrictions and guidelines for use | 46 |
| 12.1 | Restrictions | 46 |
| 12.2 | Guidelines | 46 |

1 Document management

1.1 Change history

| Date | Document Version | Created | Approved | Changes |
|------|------------------|---------|----------|---------|
| | | | | |
| | | | | |
| | | | | |
| | | | | |
| | | | | |

2 Safety



This chapter contains general safety information, specific safety instructions and precautions as well as information concerning personnel qualification and proper use of the product.

Before installing the CMS, review this manual carefully and consult with a licensed contractor, and trained installation expert to ensure compliance with local building practices, climate conditions, safety standards, and state and local codes.



2.1 General safety information

The following four risk levels and one information level are taken into account in this manual.



Danger

| | |
|---|--|
|  | DANGER |
|  | Immediate pending danger Indicates an immediately pending danger that will result in death or serious injury if not avoided. <ul style="list-style-type: none">▶ Instruction 1 to avoid danger▶ Instruction 2 to avoid danger▶ Instruction n to avoid danger |

Warning

| | |
|---|--|
|  | WARNING |
|  | Potential pending danger Indicates a pending danger that could result in death or serious injury if not avoided. <ul style="list-style-type: none">▶ Instruction 1 to avoid danger▶ Instruction 2 to avoid danger▶ Instruction n to avoid danger |

Caution

| | |
|---|---|
|  | CAUTION |
|  | Potential pending danger Indicates a pending danger that could result in minor injuries if not avoided. <ul style="list-style-type: none">▶ Instruction 1 to avoid danger▶ Instruction 2 to avoid danger▶ Instruction n to avoid danger |

Notice

NOTICE

Danger of damage to property

Indicates potential for damage to property. Is used to highlight actions that are not associated with personal injury.

- ▶ Instruction 1 to avoid damage to property
- ▶ Instruction 2 to avoid damage to property
- ▶ Instruction n to avoid damage to property

Note



Notes indicate important information about the product in the context of the manual.

- ▶ Info 1
- ▶ Info 2
- ▶ Info n

The safety instructions are supplemented by warning pictographs indicating the source and type of danger.

2.2 Safety instructions

All safety instructions in this manual are based on the results of the risk assessment carried out in accordance with the Machinery Directive 2006/42/EC Annex I and EN ISO 12100. Where applicable, the life cycle phases of the product were taken into account.



WARNING



Injury through suspended load or lifting equipment

Persons in the vicinity of the installation site immediately before the CMS being installed can be injured by lifting equipment or suspended loads.

- ▶ Secure the installation site against unauthorised access.



WARNING



Injuries from swinging load

Risk of injury through CMS swinging while suspended. Through swinging, the danger zone increases.

- ▶ Pay attention.
- ▶ Keep the escape zone clear.



WARNING



Squeezing or crushing of hands

During installation of the CMS on the charger, hands can be squeezed or crushed between CMS and charger.

- ▶ Pay attention.
 - ▶ Do not reach between CMS and Charger until the CMS is securely in position.
-



WARNING



Injury from falling objects

Risk of injury through CMS falling during setup.

- ▶ Do not stand under lifted loads.
 - ▶ Use appropriate hoisting gear.
 - ▶ If necessary, secure mechanically whilst lowering.
-



CAUTION



Tripping over charging cable

Charging cables pose a trip hazard.

- ▶ Secure cables when they are not in use.
 - ▶ Pay attention during charging.
-



CAUTION



Risk of cutting

Risk of cutting hands on CMS enclosure during unpacking and installation.

- ▶ Wear protective gloves.
-



CAUTION



Injuries through being struck by falling objects

Loose equipment or quickly deposited tools may fall and cause injury.

- ▶ Ensure that you have enough room to carry out your work.
 - ▶ Put tools away securely.
 - ▶ Keep the workplace tidy.
-

3 About this manual

3.1 Validity

This instruction regards of Cable Management System (called CMS), which is intended to guide you through the tasks of installation and service on UFC 200 and UFC 500, which are equipped with Status Light Roof.



Read this manual before conducting works on CMS.

Follow all safety instructions in [Delta UFC 200 and UFC 500 Maintenance Manual](#) and working instructions in this manual.

3.1.1 Hardware version

This manual covers Cable Management System (CMS)

Hardware version

The hardware version code provides information about the charger and the available connectors

| PN | Part description | Applicable for UFC 200 and UFC 500 chargers |
|----------------------------|---|---|
| 3924299000 | CM WITH ARM SL ROOF | Suitable for 2x CCS2 cables where length of cables is 4.8 m |
| 3924052200 + 3924382800 | CM WITH ARM + CM WITH ARM - UPGRADE KIT FOR SL ROOF ASSY | 3924052200 must be upgrade with 3924382800. Suitable for 2x CCS2 cables where length of cables is 4.8 m |

Table 1: Hardware version

Abbreviations: CMS = Cable Management System

The CMS does not fit with any other charger platform from Delta. It is also not possible to apply it on UFC 200/UFC 500, where the roof area is already used to attach other elements e.g. additional lightning, weather protection roof etc. This version of CMS only fits chargers equipped with Status Light Roof.

3.2 Target groups

This manual is intended for personnel performing CMS installation on the UFC 200 or UFC 500. Before conducting upgrade tasks on the UFC, review UFC Maintenance Manual and this manual carefully and consult with a licensed contractor, licensed electrician and trained installation expert to ensure compliance with local building practices, climate conditions, safety standards, and state and local codes.

3.3 Conventions

In this manual, the different types of content are presented differently.

3.3.1 Instructions in the text

Instructions in the text include safety instructions, notes, tasks in sequence and unordered lists of items or tasks.

Safety instructions

Safety instructions are covered in document [Delta UFC 200 Maintenance Manual](#).

Task instructions

Each step of a task is indicated by an individual step. Individual tasks are separated by blue bars, the tasks are numbered in sequence. Numbered tasks must be conducted in the order shown.

| | |
|---------|--------|
| [image] | Task 1 |
| [image] | Task 2 |
| [image] | Task n |

The task is completed.

Images and information

When information is provided together with an image these blocks are separated by black bars.

| | |
|---------|-------------|
| [image] | Information |
| [image] | Information |
| [image] | Information |

Lists

In unordered list the content is displayed with triangles which mark individual items.

- ▶ Item 1
- ▶ Item 2
- ▶ Item n

4 Product description

CMS is a product which goal is to give the client relief in usage of heavy charging cables and to prevent of long charging cables laying on the ground. The benefit is the reduction of risks of damage, personal injury and to increase operators experience.

CMS is shown on the following graph:



Figure 1 - Cable Management System

In the table below, the main points concerning the CMS device are presented:

| Category | Value | Unit |
|--|-------|------|
| Weight | 30,5 | [Kg] |
| Width | 1438 | [mm] |
| Length | 683 | [mm] |
| Height | 126,5 | [mm] |
| Work area (without cables) [radius over which the arms moves] | 1196 | [mm] |

Table 3: Main dimensions

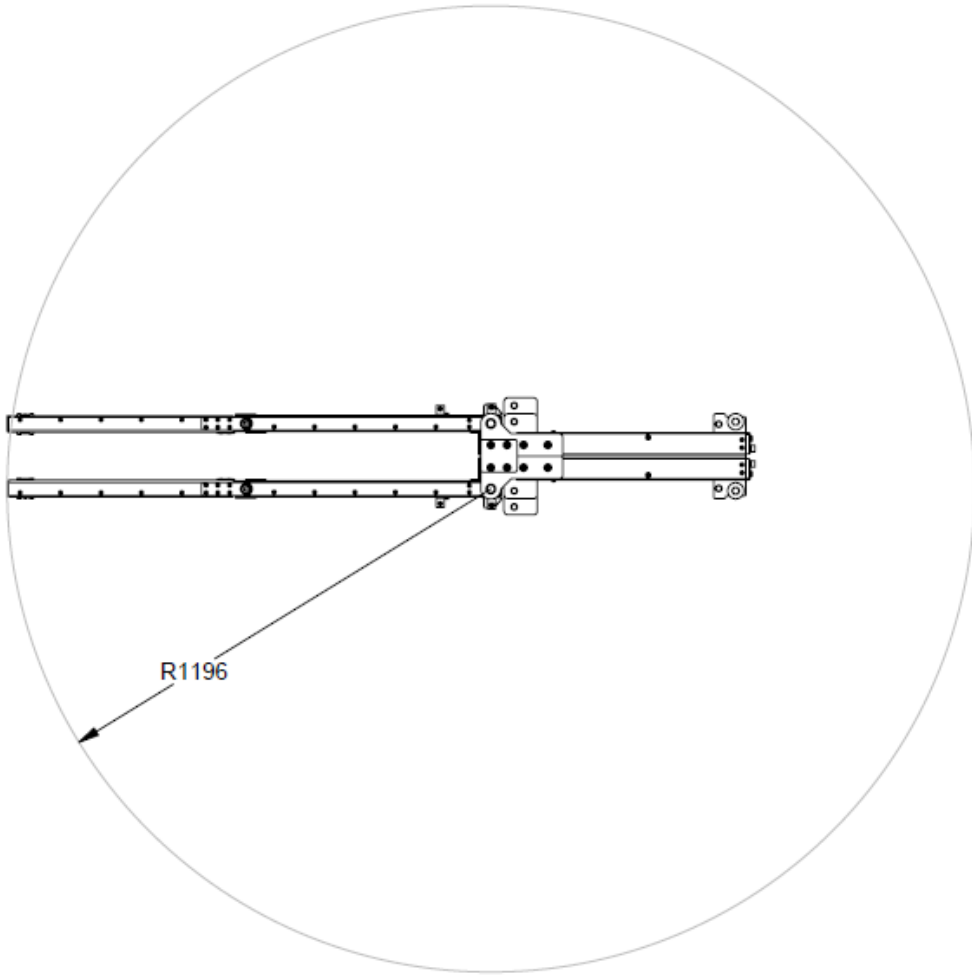

Figure 2 - CMS work area

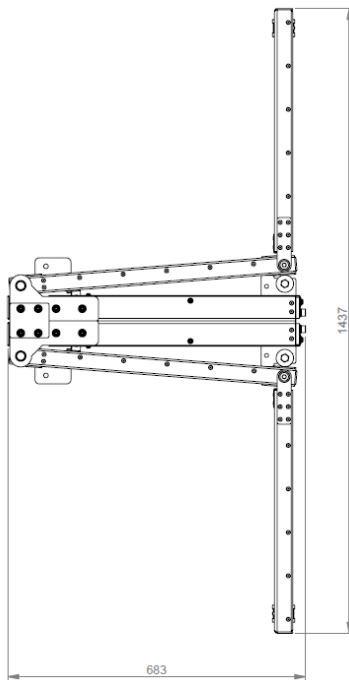

Figure 3 - CMS dimensions Width x Length

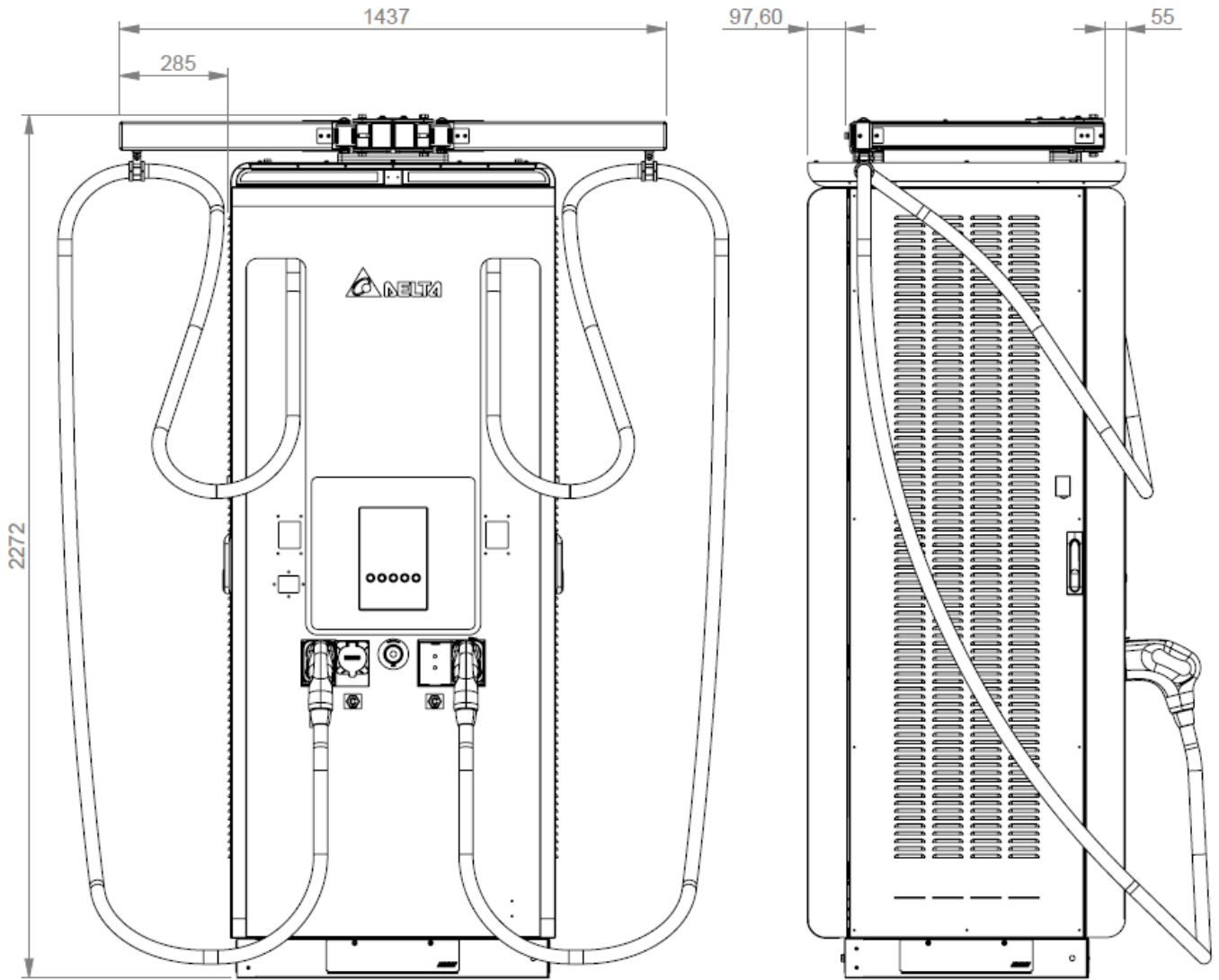

Figure 4 - CMS, dimensions on UFC200/UFC500

5 Packing and delivery

One CMS set will be delivered on a pallet containing 5 to 7 CMS units in different cardboards. This is illustrated in the photo below.



Figure 5 - Stacked 5 sets of CMS

5.1.1 Package contents

The package 3527442700 (PML CMS + PACKING) containing items shown in table below:

| PART NUMBER | DESCRIPTION | QTY |
|-------------|--|--------|
| 3924299000 | CM WITH ARM ST ROOF ASSY | 1 pc. |
| 3518566700 | CARTON PACKING CMS CARDBOARD CRGD PAPER 1182*165*782 | 1 pc. |
| 3516604200 | PAD CMS CARDBOARD DIVIDER CRGD PAPER 1150*770 | 2 pcs. |
| 3511408400 | END BLOCK FILLING CMS PACKING COMB PAPER 445*270*150 | 1 pc. |

Table 4: Packing – item numbers and quantity.



Figure 6 - Packing solution

5.1.2 Unpacking

The following steps outline the tasks to be performed in order to safely unpack the CMS:

- Place cardboard with CMS in place with easy access for 2 people
- Cut the top tape to open the carton
- Cut open the side walls of the carton and then remove the outer filling along with the filling between the arms of No. 3 (Marked by red arrows) This is shown in the picture below:

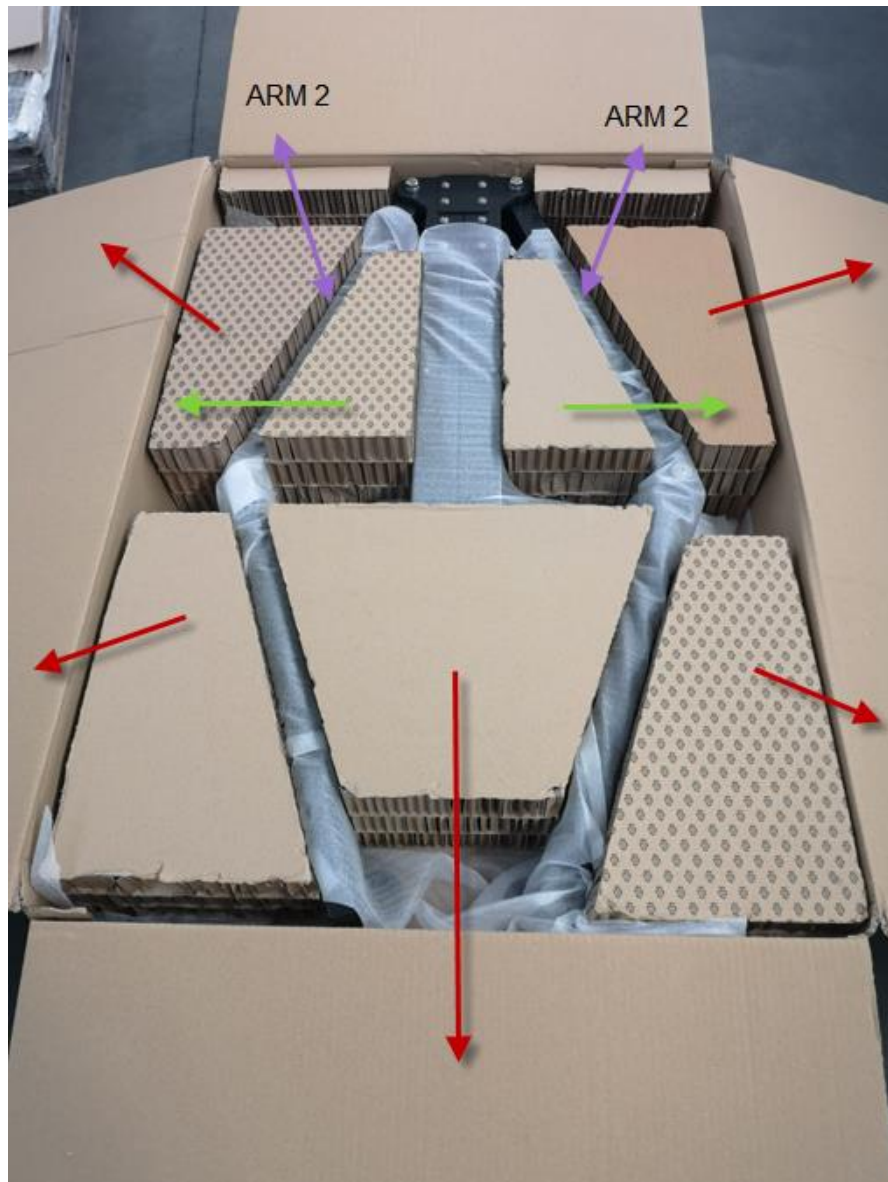

Figure 7 - Unpacking

- Remove the CMS from the cardboard grabbing front and rear wooden brackets.
- Then hold the CMS and pull out arm 2 a little to remove the inner filling (Green arrows),
- Slowly close the arm so that it makes contact with the bumper. Repeat for the other side.
- Verify that there is no visible damage to the paint or other components.

6 Preparation of the charger and space

To mount the CMS to the UFC 200 and UFC 500, the space around the charger and the charger itself must be prepared accordingly.

The points that need to be made are outlined below:

- Remove the screws together with the washers from the status light roof.

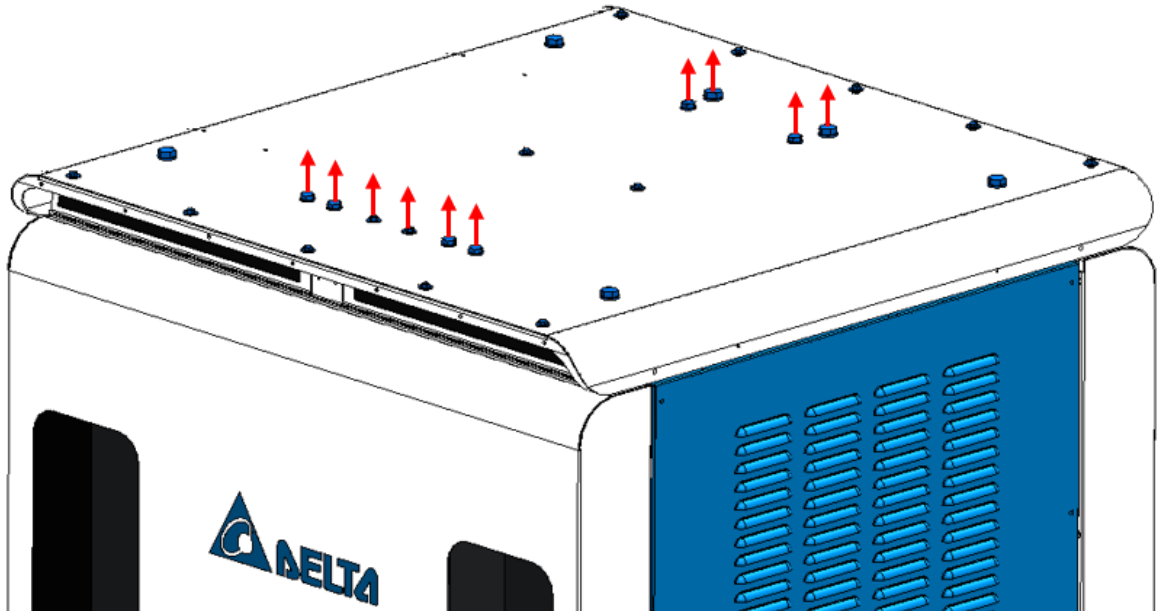

Figure 8 - Screws removal process

- Screw in the positioning pins to a distance of 8mm. The pins are included in the accessory kit of Roof under CM ASSY.

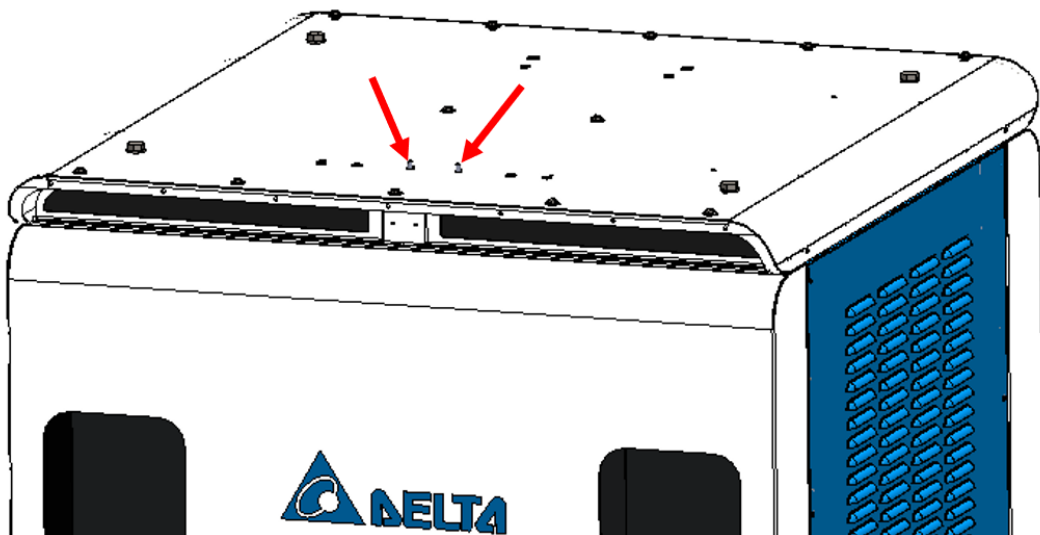

Figure 9 Screwing in the positioning pins

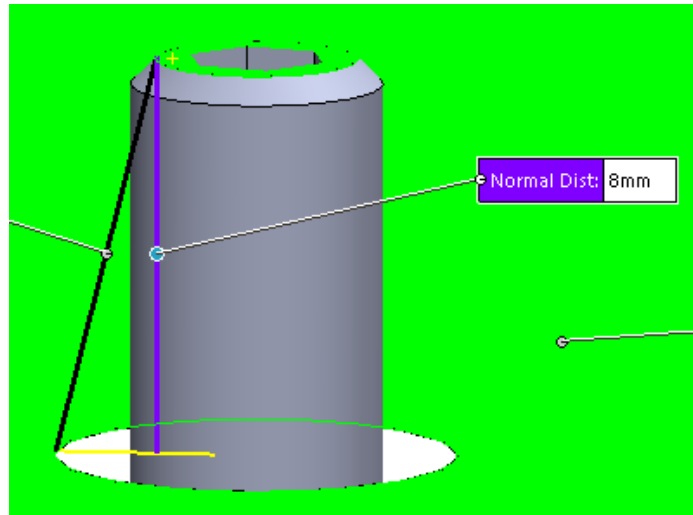

Figure 10 The distance to which the positioning pins should be screwed in

- Clean the roof of the charger of any debris such as dirt, dust, water

After installation/service

After installing the system, leave the charger clean. Dispose of any waste in a suitable waste container. During and after servicing operations, any soiling, e.g. with grease, must be cleaned up.

7 CMS set material preparation

For the purpose of the CMS assembly, user will receive set of elements necessary for CMS. Pictures below are showing CMS which will be helpful for the client to realize the full view on the solution. In the pictures item numbers which will be useful for parts identification.

7.1 Construction elements

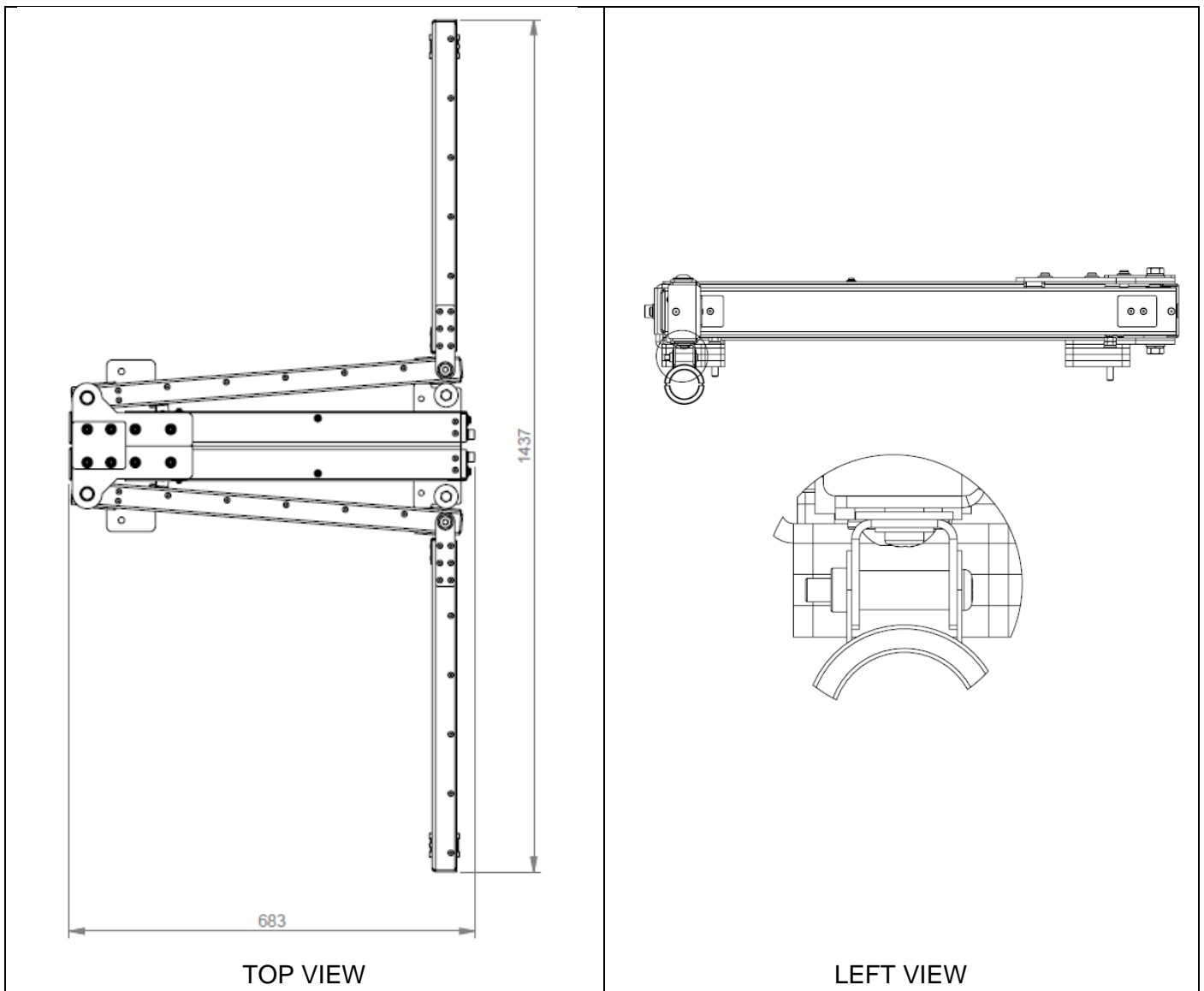

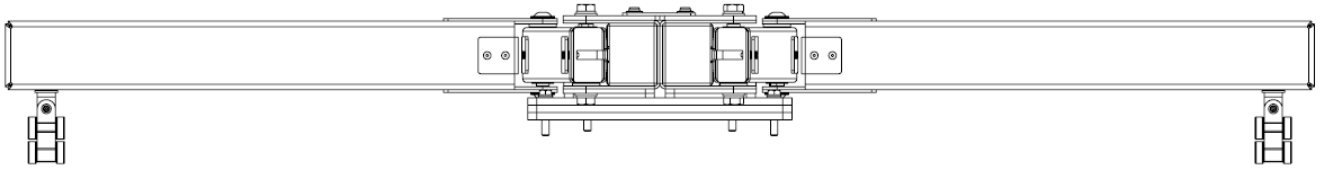

FRONT VIEW WITH PARTS ASSEMBLY NUMBER INDICATION

7.2 Arm and clamps

Client will receive 2 sets of cable clamps equipped with holding elements.

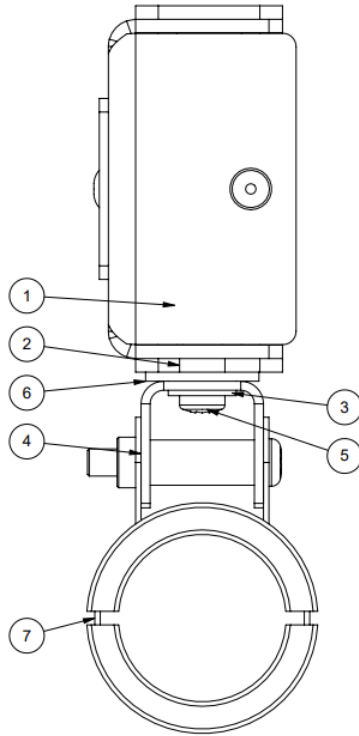

Figure 11 - View on cable clamp and mounting point in arm with parts assembly number indication.

| 7 | 3902561000 | CLAMP CMS ASSY | 1 |
|------|-------------|---|-----|
| 6 | 3247076800 | WASHER ESSENTRA 1008870000VR, 10.2 x 25 x 2 | 1 |
| 5 | 3105701900 | SCREW M M5*0.8*16 PAN TORX SUS | 1 |
| 4 | 3488861400 | HANDLE FOR CLAMP | 1 |
| 3 | 3110373999 | WASHER PLAIN M5*15*5.3*1.2mm SUS | 1 |
| 2 | 3433057700 | SPACER SUPPORT 10 * 5.3 * 5 | 1 |
| 1 | 3902429400 | ARM 3 RIGHT ASSY | 1 |
| ITEM | PART NUMBER | DESCRIPTION | QTY |

Table 7: Arm, mounting point elements, cable clamp and insertion rubber Part Numbers.

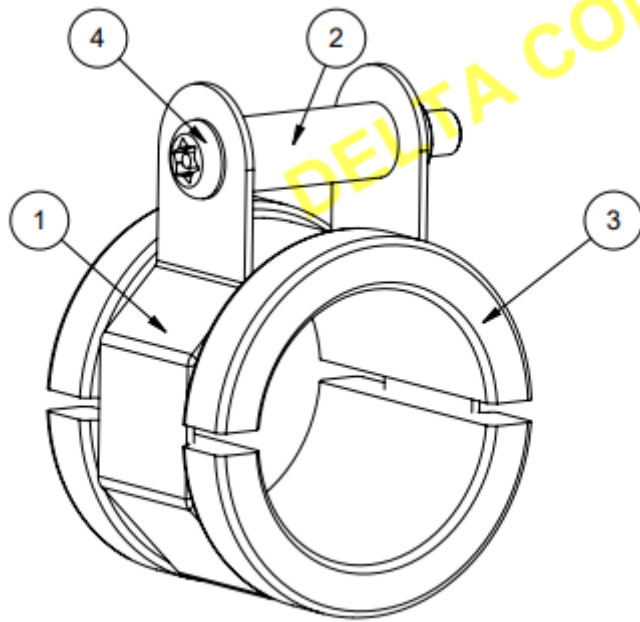

Figure 12 - Clamp assembly

| 4 | 3101720100 | SAFETY SCREW A2 M6x40 TX-PIN 30 | 1 |
|------|-------------|---------------------------------|-----|
| 3 | 3430437200 | SLEEVE CCS2 REMA | 2 |
| 2 | 3431014200 | TUBE 10x1,5 | 1 |
| 1 | 3487845000 | CLAMP RING | 1 |
| ITEM | PART NUMBER | DESCRIPTION | QTY |

Table 8: Bill of materials for Clamp Assembly.

8 CMS Assembly instruction

This chapter covers the installation of CMS to the UFC 200 or UFC 500 equipped with Status Light Roof.

8.1 Requirements and restrictions:

- Installation must be performed by 2 persons and crane/forklift.
- Installation should take place under dry conditions to prevent against water entering the charger and between the CMS and the charger.
- Do not perform any tasks that are not listed in the manual.

8.2 Tools preparation

8.2.1 First assembly

To perform the upgrade, following tools must be available

- ▶ Torque wrench 2-100Nm
- ▶ Hexagonal socket wrench key 8 mm
- ▶ Hexagonal socket wrench key 13 mm
- ▶ Hexagonal socket wrench key 17 mm
- ▶ Screwdriver bit TX T25
- ▶ Security tamper resistant key TX30
- ▶ Hex-L key 6 mm
- ▶ Technician tent
- ▶ Ladder
- ▶ Safety helmet
- ▶ Protective gloves
- ▶ Safety shoes

8.2.2 Service of CMS

- ▶ Screwdriver bit T20/T25/T30
- ▶ Hexagonal socket wrench key- 5,5;7;8;10;13;17;19
- ▶ Hex-L key 2,5;4;5;6;8 mm
- ▶ Torque wrench 2-100Nm
- ▶ Wrench key (flat) 17 mm
- ▶ Technician tent
- ▶ Ladder
- ▶ CX80 CHAIN LUBE
- ▶ Safety helmet
- ▶ Protective gloves
- ▶ Safety shoes

8.2.3 Service parts for crane/forklift usage

Part 3535108700 is not standard CMS equipment and is not included. To perform installation with crane usage it is needed to have service tool from table below.

| PART NUMBER | DESCRIPTION | QTY |
|-------------|--|-------|
| 3535108700 | M/E KIT ASSY CMS LIFTING KIT FOR SERVICE | 1 pc. |

8.3 Installation instruction

This part will lead through CMS structure assembly, then its installation and finally connection with cables.

8.3.1 Structure assembly

First part will be focused on assembly of CMS construction. Items numbers shown in this chapter will be corresponding with Drawing 3924382800. This chapter only applies to the upgrade of the standard version of CMS (3924052200) using upgrade kit (3924382800). 3924299000 is ready for use and does not require this upgrade.

| ITEM | PART NUMBER | DESCRIPTION | QTY |
|------|-------------|---|-----|
| 1 | 3484722300 | SPACER FRONT ST ROOF UPPER AL 290*82.50*8 | 1 |
| 2 | 3484721600 | SPACER FRONT ST ROOF LOWER AL 290*82.50*8 | 2 |
| 3 | 3484721500 | SPACER BACK UPPER | 1 |
| 4 | 3488862000 | SPACER BACK | 2 |
| 5 | 3479535600 | DAMPER BUMPER RUB 40*13.5*40 BLK | 2 |
| 6 | 3105666600 | SCREW M M10*1.5*65 HEXH SUS | 2 |
| 7 | 3105099798 | SCREW DIN 933 M8X45 HEX A2 SUS | 4 |
| 8 | 3105098998 | SCREW DIN 933 M8X25 HEX A2 SUS | 2 |
| 9 | 3105098000 | SCREW DIN 933 M8X35 HEX A2 SUS | 2 |
| 10 | 3105743800 | SCREW M M5*0.8*20 FLAT HEXI SUS | 4 |
| 11 | 3110396699 | WASHER PLAIN M10*30*10.5*2.5mm SUS | 2 |
| 12 | 3110373600 | WASHER, FLAT DIN125 M8 8,4/16/1,6 A2 SUS | 6 |
| 13 | 3110256300 | WASHER, SPRING DIN 127 M8, A2 SUS | 6 |
| 14 | 3111110700 | NUT, DIN934 M10 HEX A2 SUS | 2 |
| 15 | 3110131400 | NUT, DIN934 M8 HEX A2 SUS | 2 |
| 16 | 3110132800 | NUT HEXH+NYLON M8*8 S18C NI | 2 |

Table 9 Bill of materials for upgrade kit

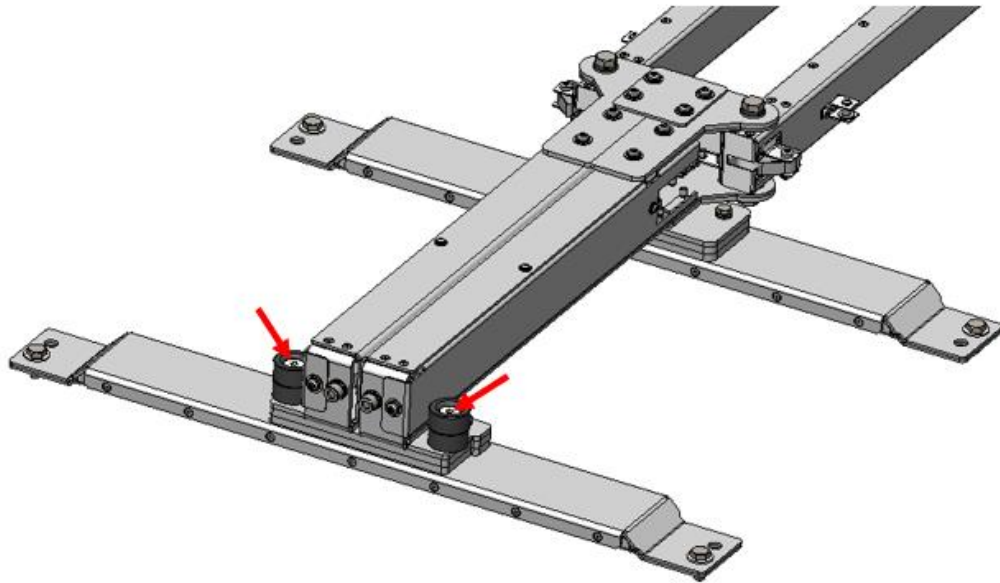

1. Unscrew the screws marked with the red arrows and remove rubber bumpers.

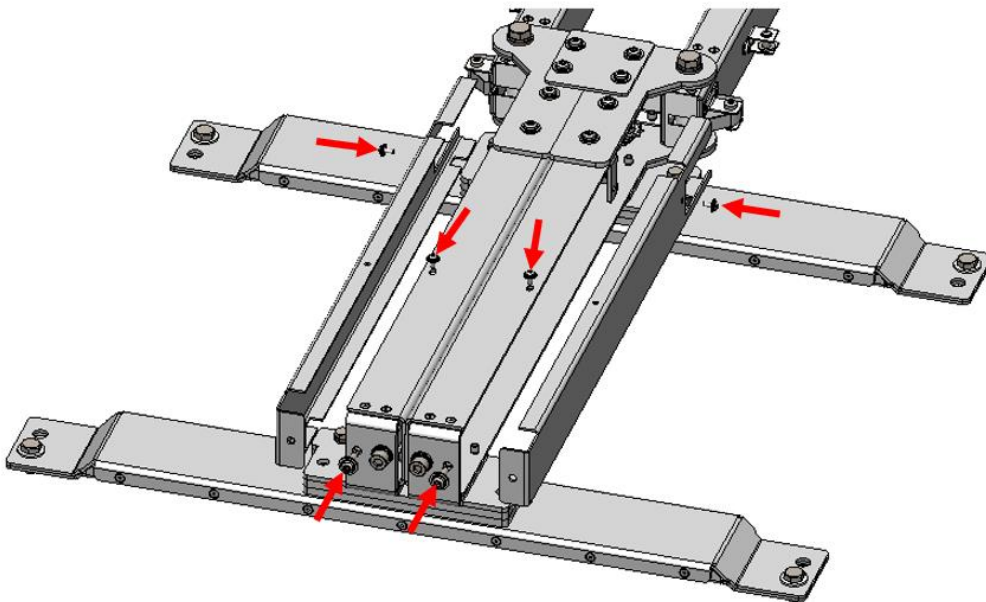

2. Unscrew the screws marked with the red arrows and remove chain covers on both sides.

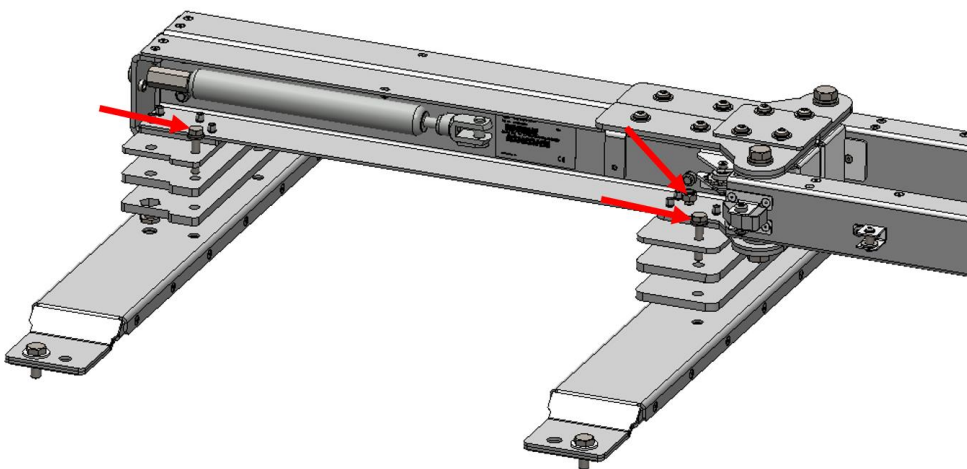

3. Unscrew the screws and nuts marked with the red arrows and separate beams and distance spacers from the main part of CMS.
-

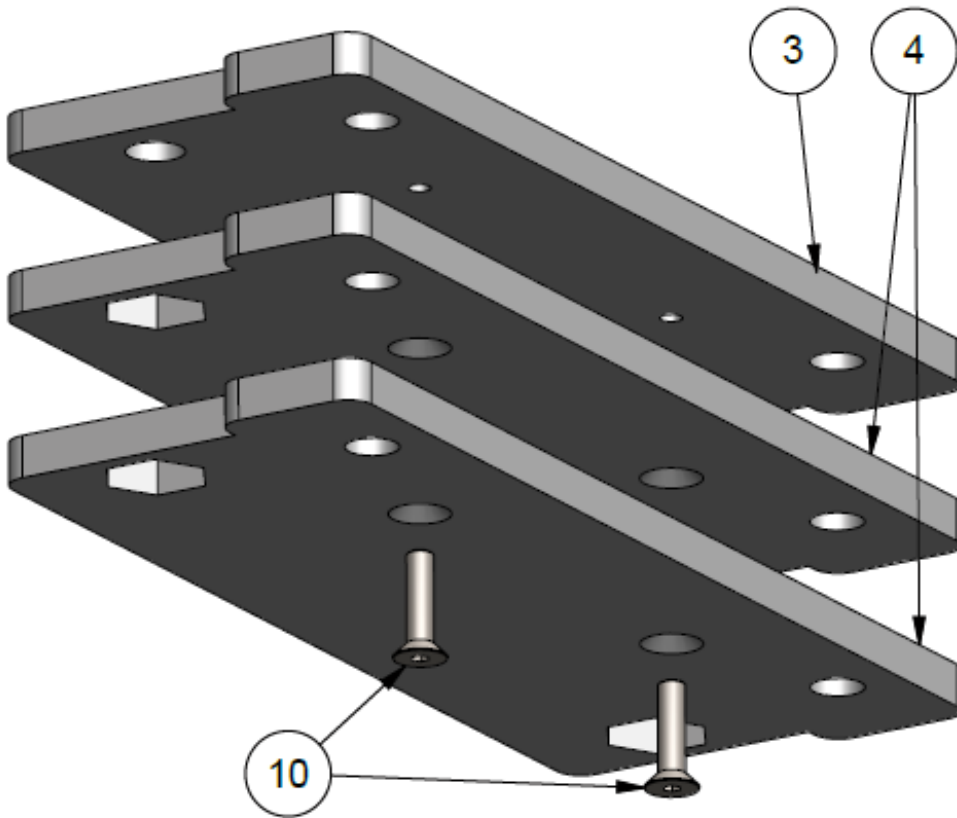

4. Screw the rear distance spacers (3484721500 1pcs., 3488862000 2pcs.) included in the upgrade kit (3924382800) together, like it's shown on the picture.

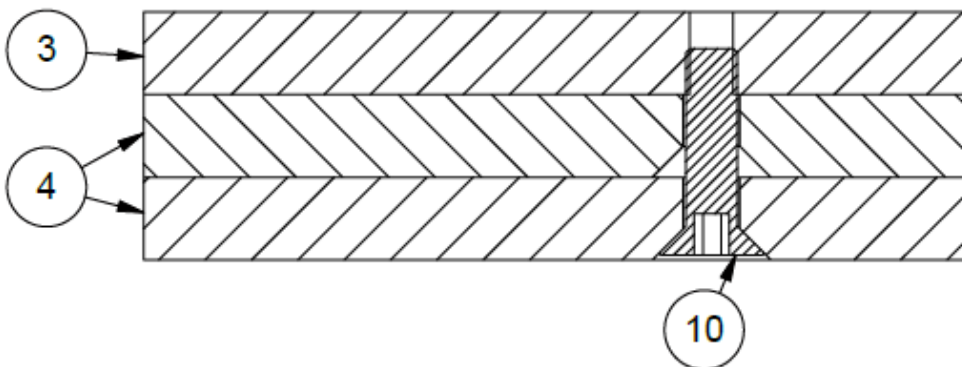

5. Pay attention to the correct sequence of the distance spacers (3484721500 is located on the top).

6. Screw the front distance spacers (3484722300

1pcs., 3484721600
2pcs.) included in the
upgrade kit
(3924382800) together,
like it's shown on the
picture.

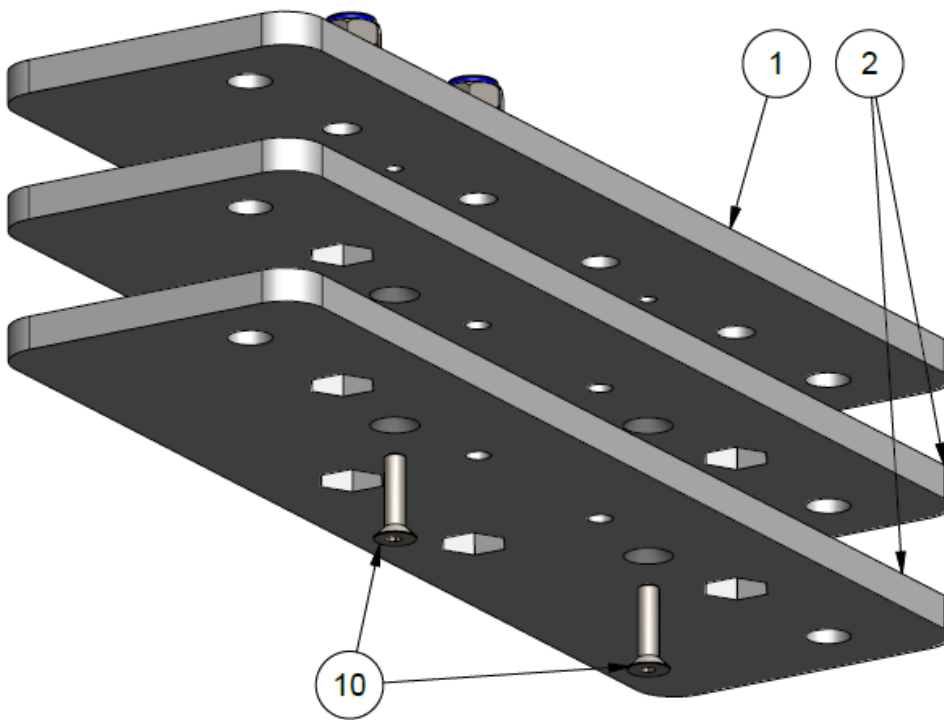

7. Pay attention to the
correct sequence of the
distance spacers
(3484722300 is located
on the top).

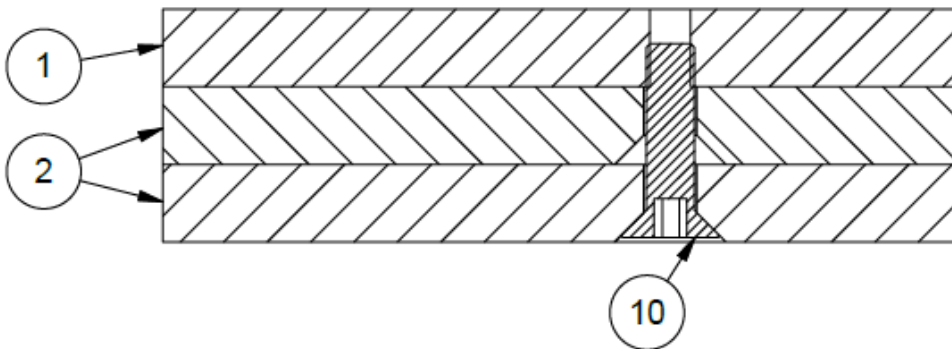

8. Screw on the front
distance spacers to the
main part of CMS.

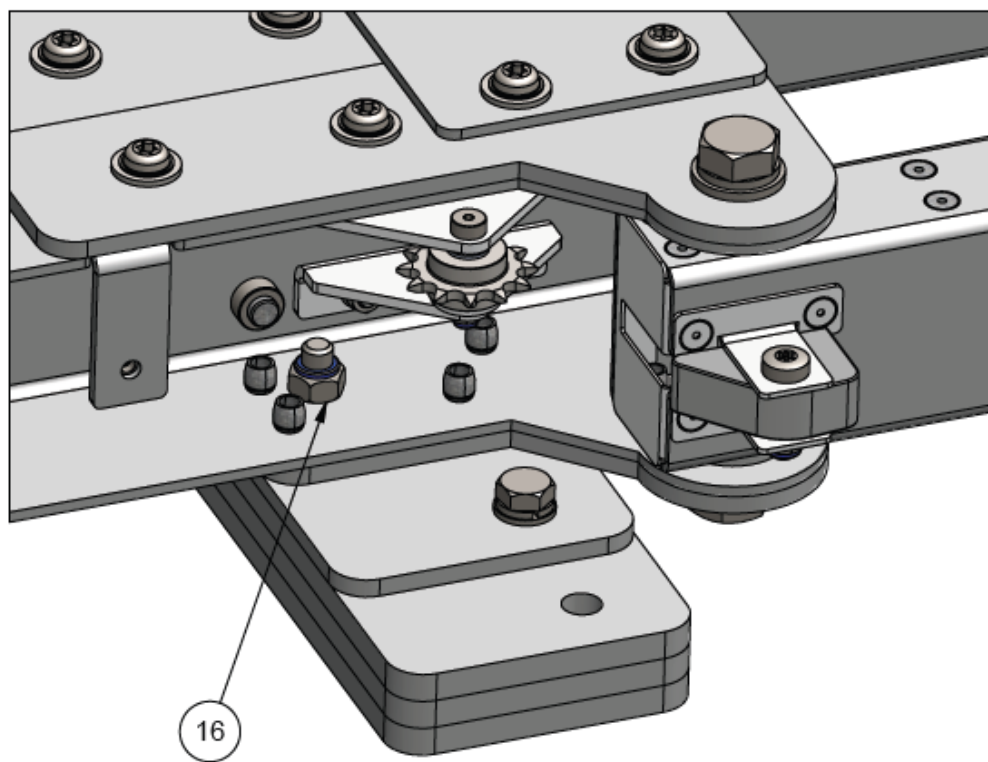
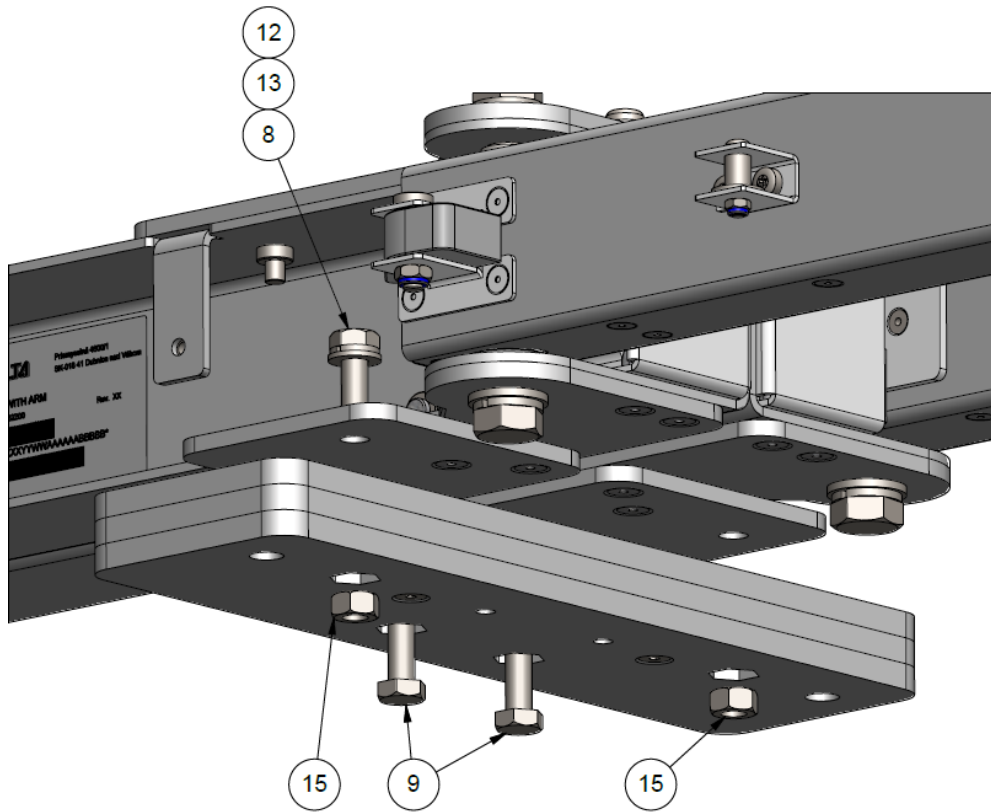

9. Screw on the nut shown on the picture. Remember to use the new nylon nut which is added to the upgrade kit.



WARNING

Injury through suspended load or lifting equipment

Persons in the vicinity of the installation site immediately before the CMS being installed can be injured by lifting equipment or suspended loads.

- ▶ Secure the installation site against unauthorised access.



WARNING

Injuries from swinging load

Risk of injury through CMS swinging while suspended. Through swinging, the danger zone increases.

- ▶ Pay attention.
- ▶ Keep the escape zone clear.



WARNING

Squeezing or crushing of hands

During installation of the CMS on the charger, hands can be squeezed or crushed between CMS and charger.

- ▶ Pay attention.
- ▶ Do not reach between CMS and Charger until the CMS is securely in position.



WARNING

Injury from falling objects

Risk of injury through CMS falling during setup.

- ▶ Do not stand under lifted loads.
- ▶ Use appropriate hoisting gear.
- ▶ If necessary, secure mechanically whilst lowering.



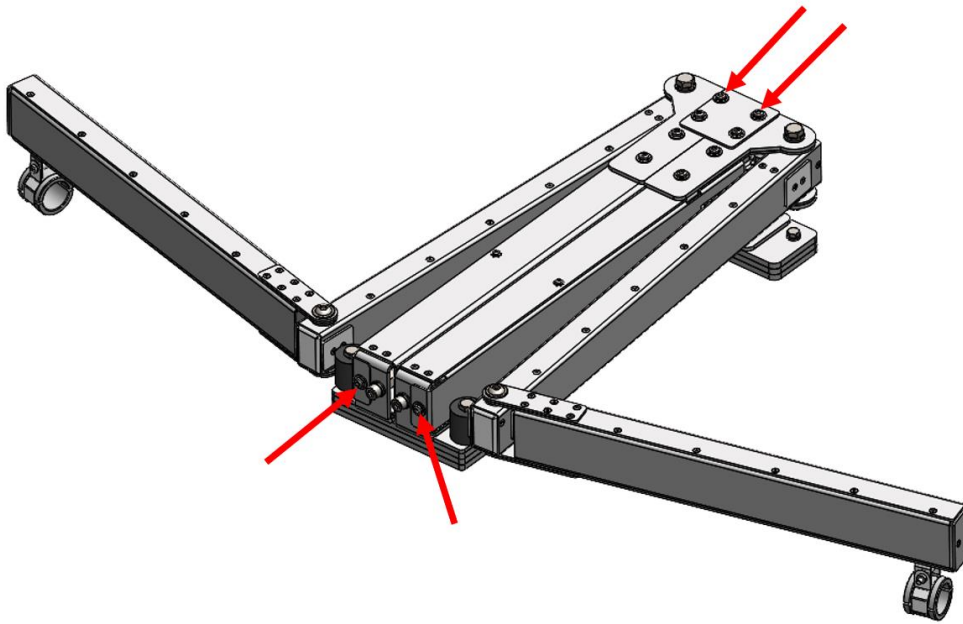

10.To Perform installations using a crane/ forklift, follow these steps:

- a) Use Service lifting kit (PN will be created) – Remove screws M6 4 pcs. and washers marked by red arrows.

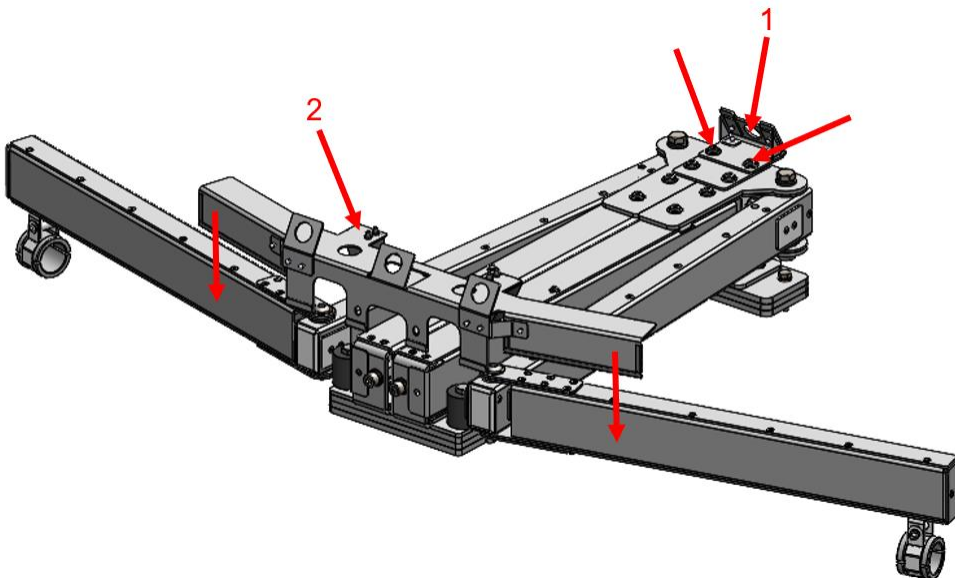

- b) Assembly part 1 (3902661300) to the CMS using screws M6 and flat washers M6 with torque 9 Nm. Insert part 2 (3902659900) from the top and connect to the CMS using screws M6 and flat washer M6 with torque 9 Nm.

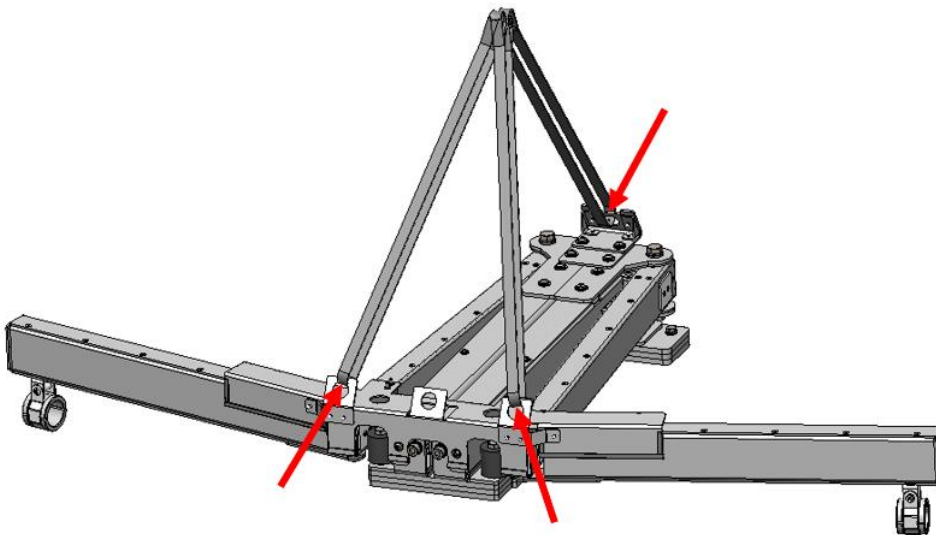
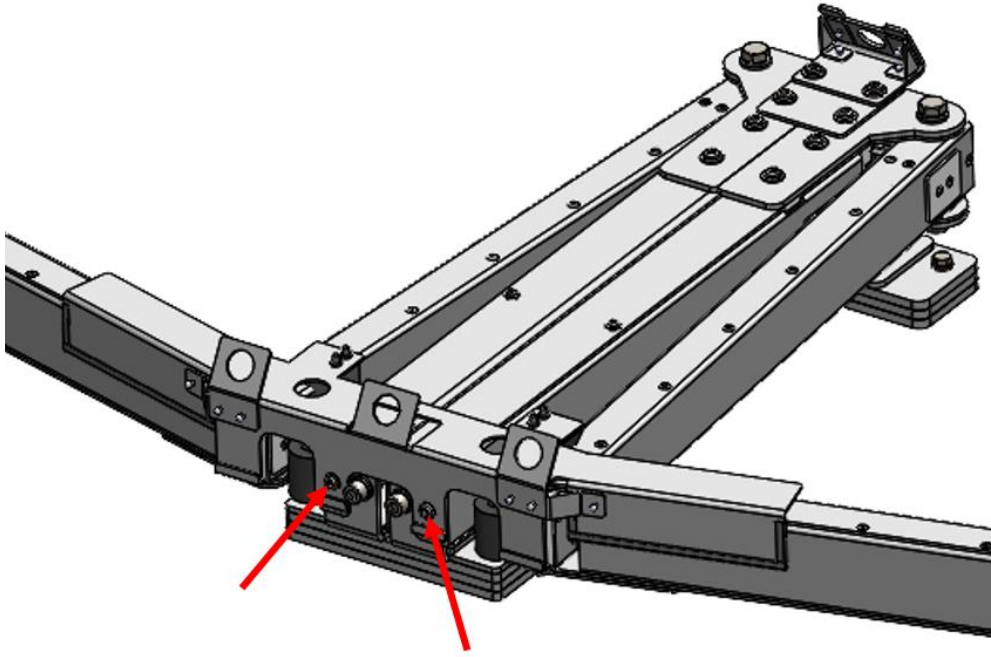

c) Put the transport belts through the holes in service parts. **It is recommended to use belts with 2 loops.**

d) When lowering the CMS onto the roof, ensure that the holes in the

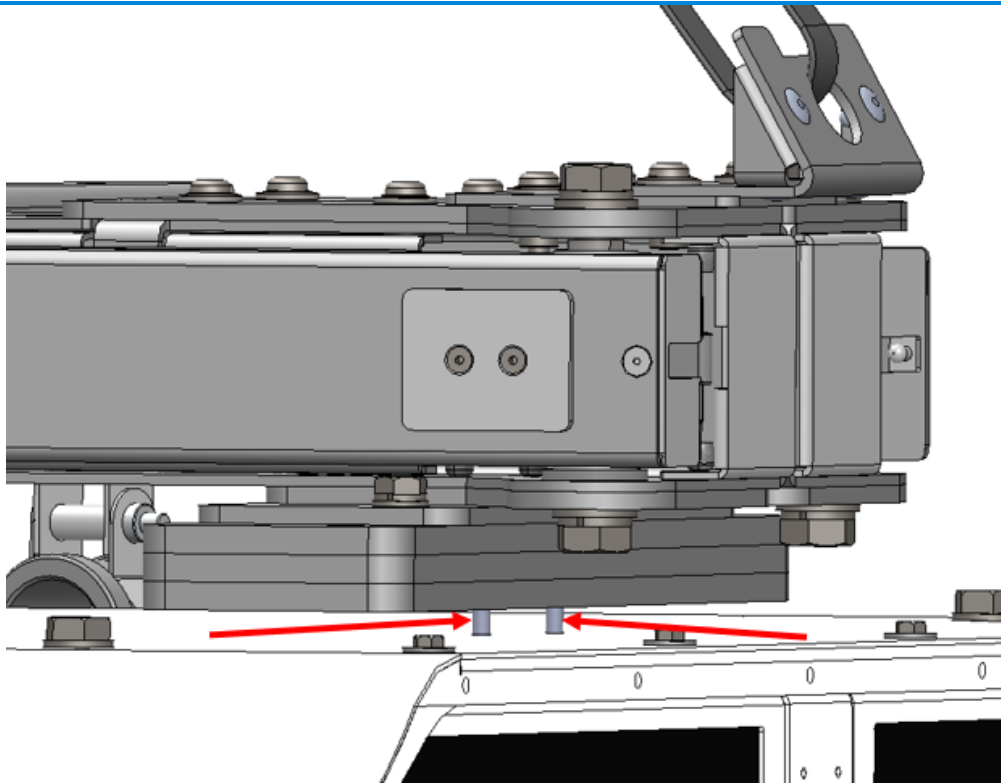

distance spacers are aimed at the positioning pins.

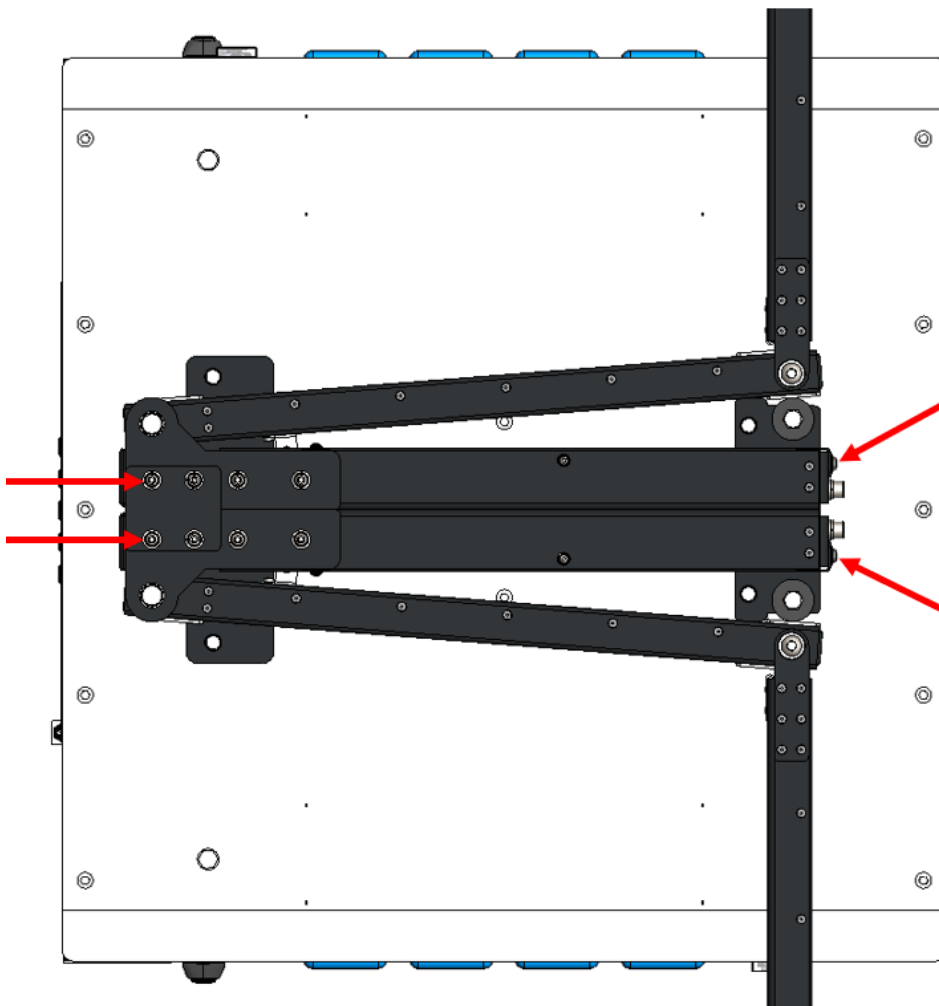

e) Insert the CMS on the roof and position it so that the holes in the CMS are axial to the holes in status light roof.

f) Remove belts and service parts for lifting (3902661300 and 3902659900) from the CMS and assembly screws M6 with washers to CMS using torque 9 Nm.

g) Connect CMS to the roof using 4 screws M8x45 (Item 7, table 9) and spring washers (Item 13, table 9) and flat

washers (item 12, table 9) using torque 17 Nm.

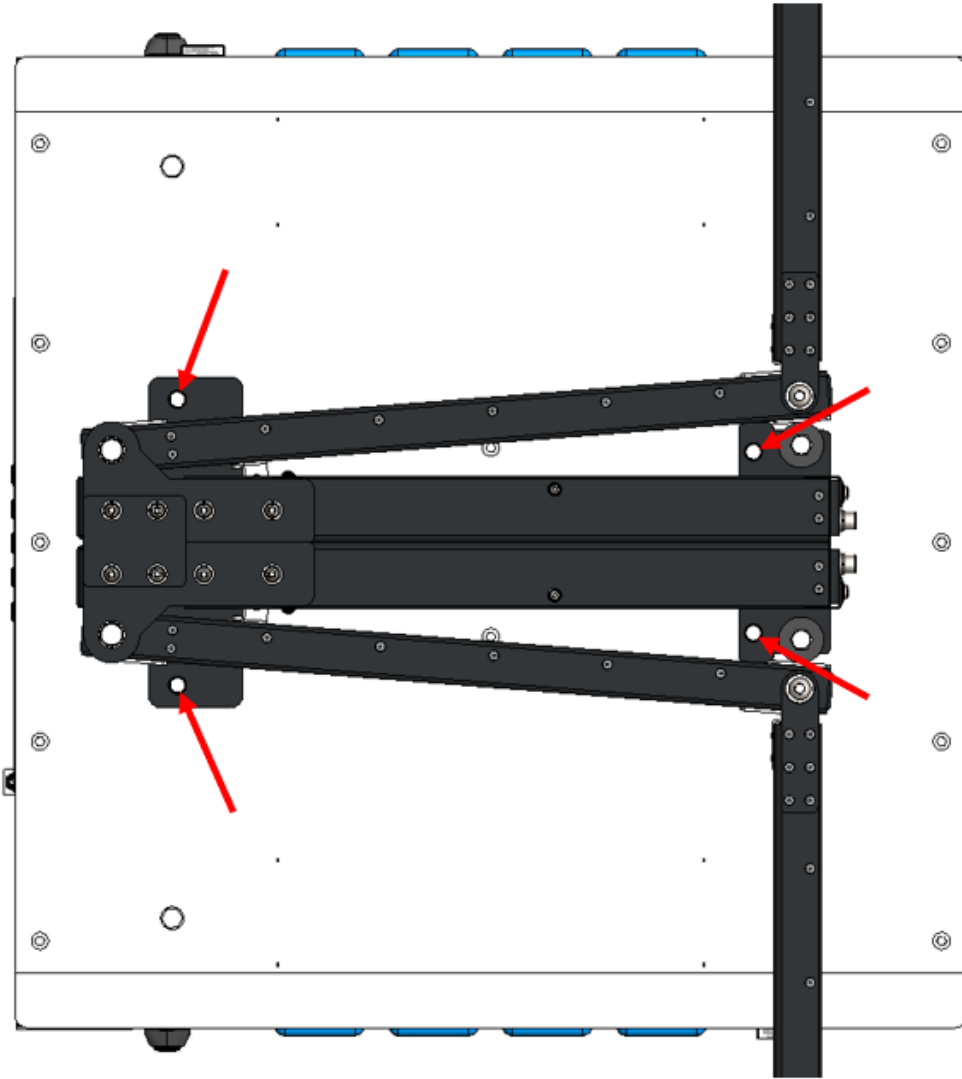

11. Straighten the wires as in the picture on the left.



12. Disassemble Clamp (Item 7, table 7) from Handle for clamp (Item 4, table 7) and connect it to the CCS cable in the distance 3.3 m from the beginning of cable gun to the center of cable clamp. **WARNING! The distance 3.3 m is a**

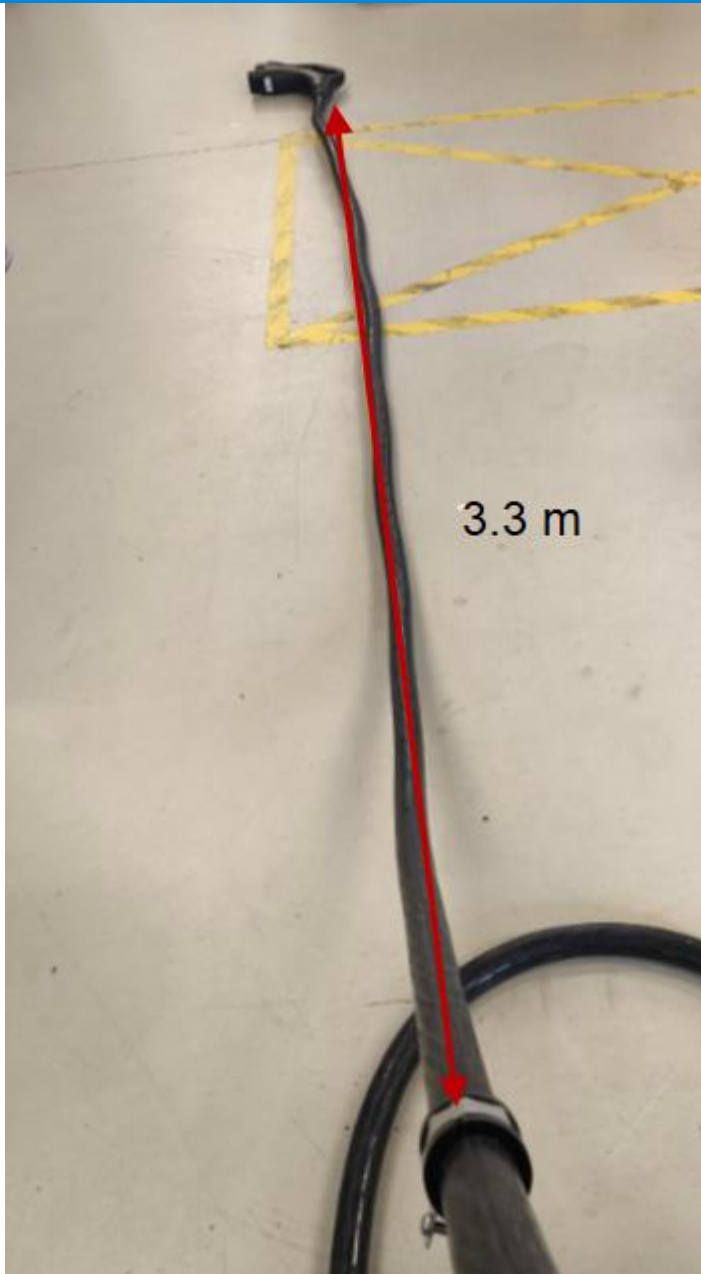

base value and depends on the length of the cable. Find the point in cable length (between cable gland and plug) which suits you from the perspective of maximum cable reach and avoiding damage of the cable by lying it on the ground.

13. Next connect clamp with cable to Arm using Tube (Item 4, table 8) and Safety screw M6x40 (Item 5, table 8) with force 9Nm.

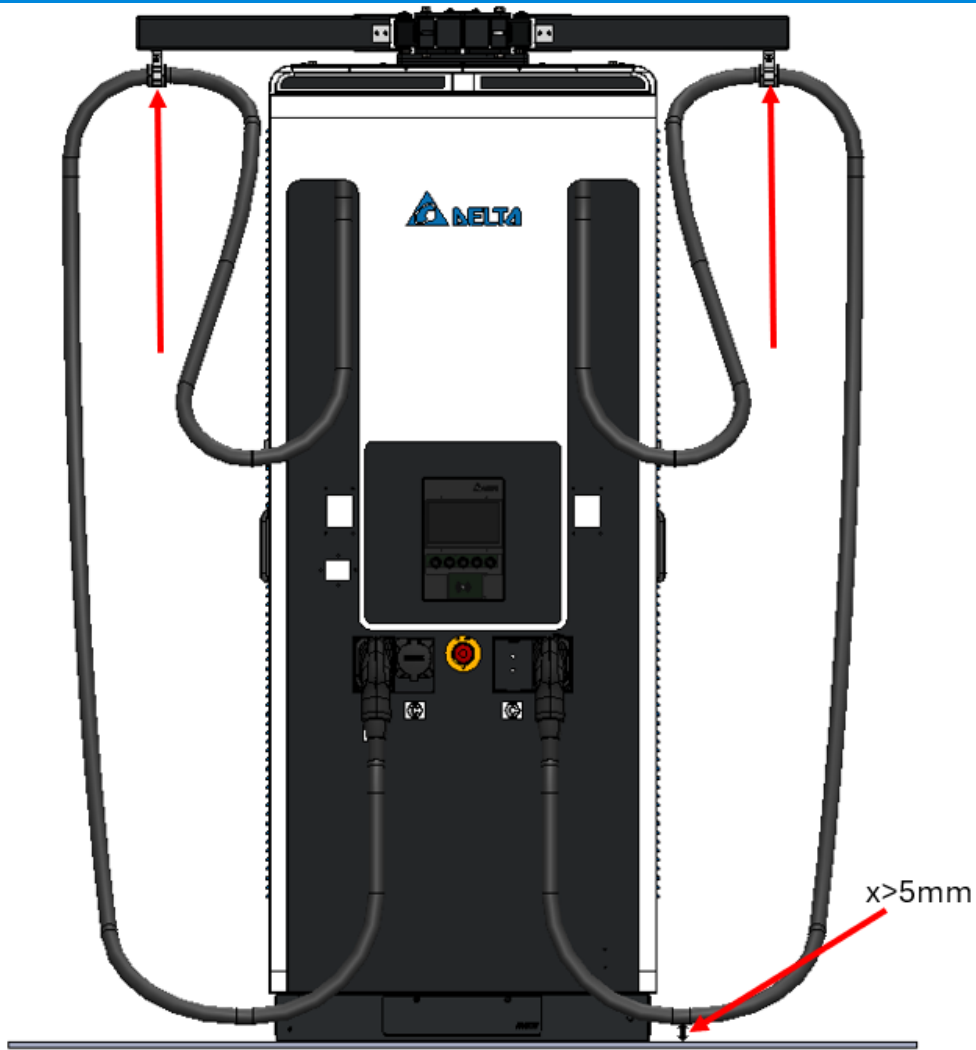

9 Verification of correct installation

A correctly mounted CMS on a charging station looks as shown in the photo below. In order to verify the correct operation of the System, the following things should be checked.

- Unplug the gun from the charger and then move the cable away from the front of the charger until the system is fully open.
- Return to the charger, holding the plug, and assess whether the system causes the arm to move back with the cable.
- Insert the plug into the gunholder and assess whether there is any strong twisting of the plug when trying to insert it into the gunholder



Figure 13 - Correctly installed CMS



Figure 14 - Correctly installed CMS

9.1.1 Example of incorrect assembly

The photo below shows an example of how the CMS is incorrectly mounted. The wires must not be allowed to twist excessively during installation. If this occurs, return to step 8.



Figure 15 – Incorrectly installed CMS

10 Maintenance inspections

This chapter covers the maintenance inspections for the CMS.

Do not perform actions that are not described in the following subsections.

10.1 General information

The CMS requires multiple inspections at different intervals.

The tasks for this inspection are listed in the following chapter.

The yearly preventive maintenance inspection must be conducted every 12 months. The results of this inspection must be recorded in the preventive maintenance checklist and sent to Delta.

The 2 year periodic check focuses on a general check of the entire CMS and must be conducted every 24 months.

10.2 Chain inspection

The chain should be checked every year. This involves checking that the chain is not damaged, e.g. that it has not been pulled out and that the pretension value ($A+2\div 6$ mm) is not within the range of values specified in the documentation, i.e. drawing 3924052200. It is also necessary to check that the chain is not dirty or that lubrication is required. If the chain is dirty, it must be cleaned and lubricated, either by protecting the inside of the CMS from dirt or by removing the chain.

It should also be verified that there is no damage to the sprocket assembly, e.g. the sliding sleeve, the shoulder screw and the sprocket itself.

10.3 Gasspring Inspection

During the annual servicing, the gasspring should be verified. The check should be carried out by fully opening the arm (with the cable connected) and then verifying that the mechanism works correctly, i.e. the arm touches the rubber buffer.

Before checking, make sure that the wires are fitted correctly and that there are no twisted wires.

Gasspring should be replaced after 10,000 cycles or 2 years of use.

10.4 Rotary joint inspection

Visually verify that the sliding sleeve in the joint, has not been damaged. Whether the bushing has rubbed off, causing the arm to drop significantly. Measure the distances between the arms and the beams as detailed in the checklist and compare the values from the checklist with the current measurements and write them down. The check should be carried out every year.

10.5 General CMS inspection

A general inspection of the CMS unit should be carried out every 2 years. The unit should be checked for corrosion, paint damage or damage to other components. In addition, it is important to verify each year that the paint on the charger has not been damaged by contact with the wires.

10.6 Clamp inspection

Verification of the clamp should be carried out annually. It should be checked to ensure that none of the components are damaged. To do this, disassembly the clamp and check the wear of the brass bushing (PN: 3433057700) in the assembly 3924052500 and 3924052300. After successful verification, the clamp should be fitted with Loctite 2400 / Loctite 243. If there is damage to the bushing, it should be replaced.

The next step is to check that the insulation of the wires has not been damaged. This can be manifested by rippling of the insulation.

10.7 Service card

| TYPE | INTERVAL | COMMENTS |
|--------------------|----------|----------|
| GASSPRING | 1 year | |
| CLAMP | 1 year | |
| CHAIN | 1 year | |
| ROTARY JOINT | 1 year | |
| GENERAL INSPECTION | 2 years | |
| CABLES | 1 year | |
| CHARGER PAINTING | 1 year | |

10.8 Contraindications

Do not carry out operations not listed in the instructions. It is strictly forbidden to lubricate the sliding bushings and the rotary joints in arms in general as this will damage the bushings. When lubricating the chain, do not get the unit dirty.

11 Gasspring replacement

This chapter covers the replacement of Gasspring in CMS

11.1 Requirements and restrictions:

- Gasspring replacement must be performed by 2 persons.
- Do not perform any tasks that are not listed in the manual.

11.2 Tools preparation

11.2.1 Gasspring replacement

- ▶ Screwdriver bit TX20/TX30
- ▶ Screwdriver bit Hexagonal socket 8 mm
- ▶ Torque wrench 2-50Nm
- ▶ Wrench key (flat) 17 mm
- ▶ Technician tent (optional)
- ▶ Ladder (2 pcs.)
- ▶ Safety helmet
- ▶ Protective gloves
- ▶ Safety shoes

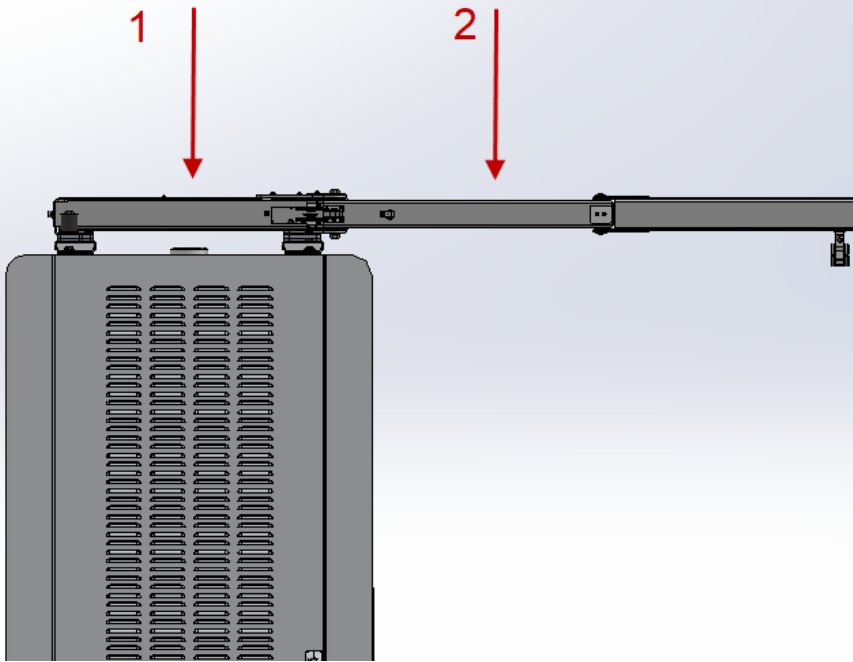

1. Disconnect the cable from the cable clamp by removing the M6x40 screw.
2. Open CMS arms (one person should hold arm 2 at all times when performing service work (place marked by arrow and number 2), unless otherwise written). Second operator should have access to place marked by arrow with number 1.

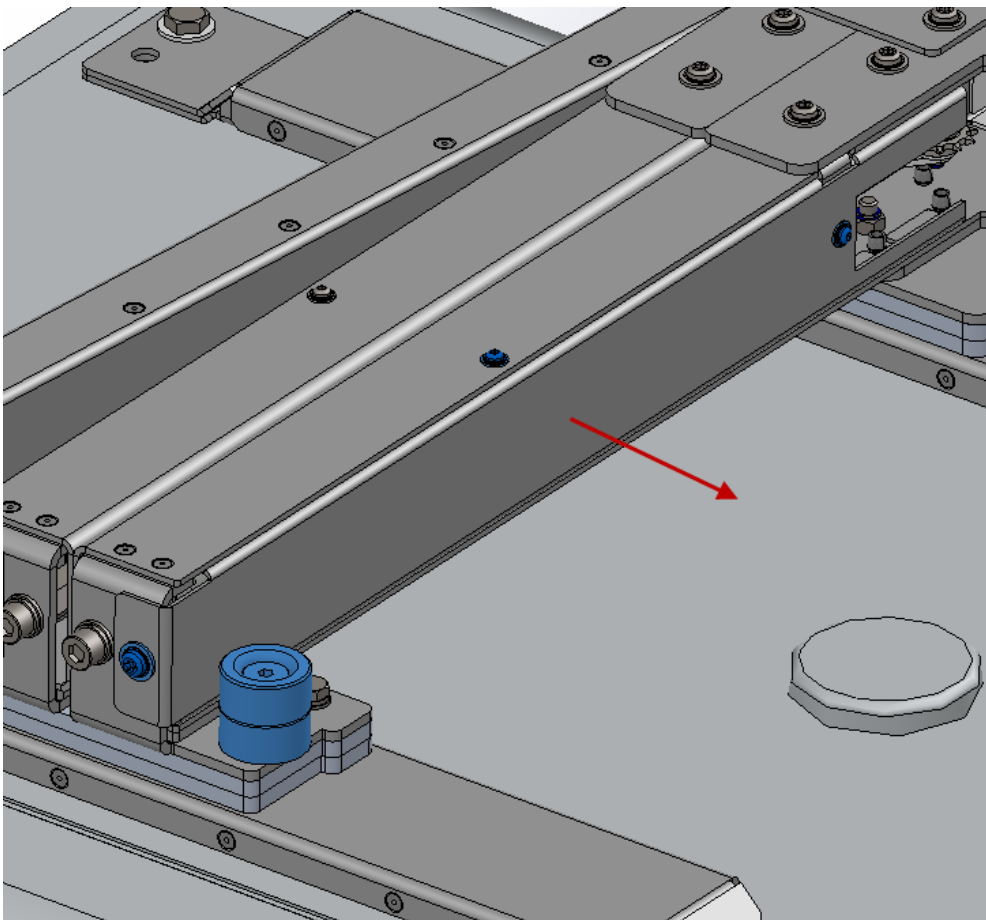

3. Remove bumper with screw M10 and remove Cover ARM 1 by removing screws (M6 - 1 pc. and M4 - 2 pcs.). After cover removal reinstall bumper using screw M10 and torque 10Nm. (Check whether it is possible to remove cover without removing bumper, if so, you can do that)

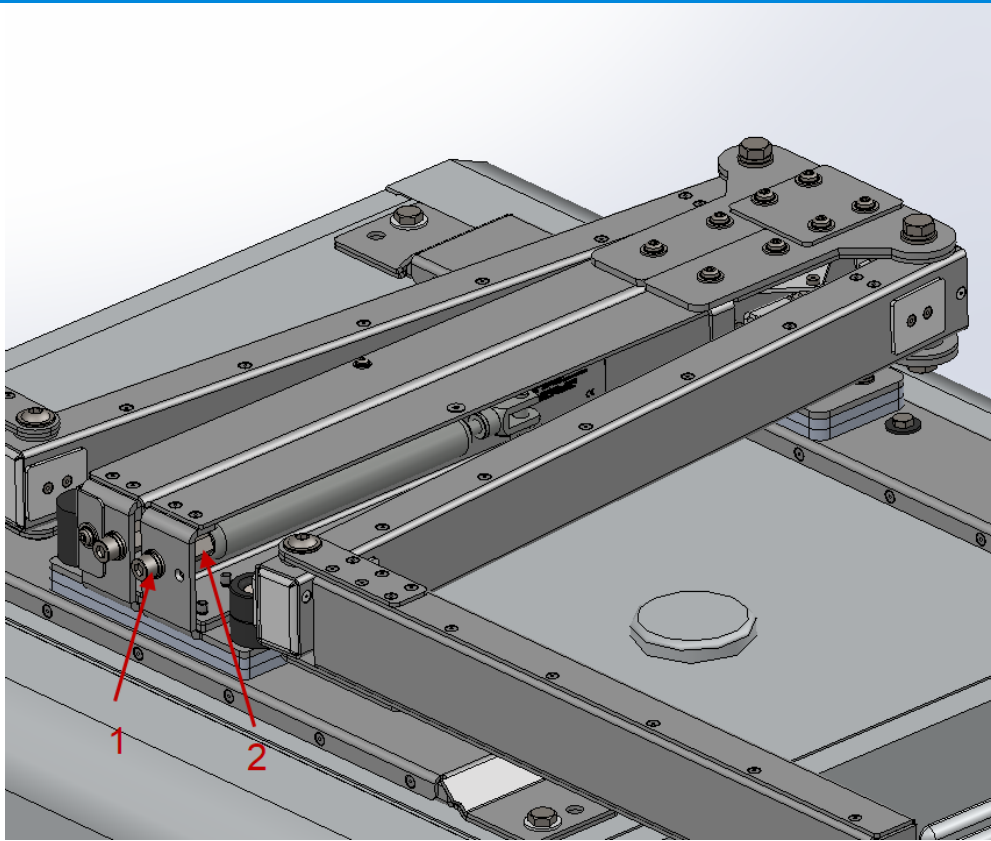

4. Place CMS in position shown in picture on the left side. To remove gaspring use wrench key 17 mm on standoff to block rotation of the gaspring and next remove screw M10 with washers (arrow with number 1).

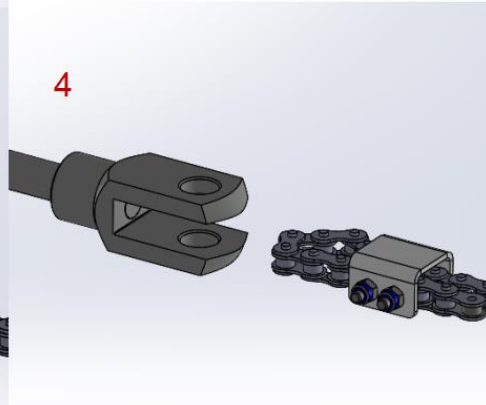
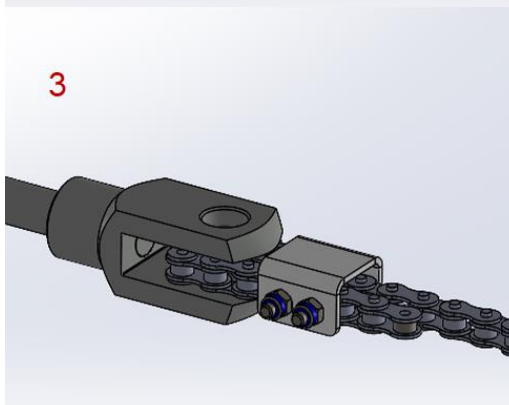
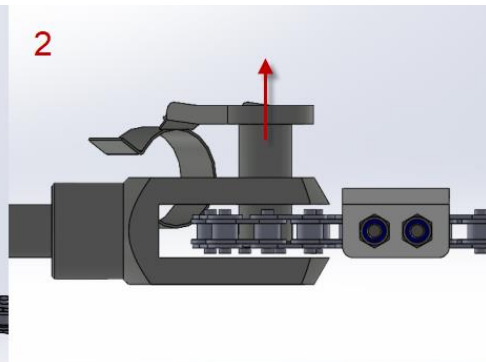
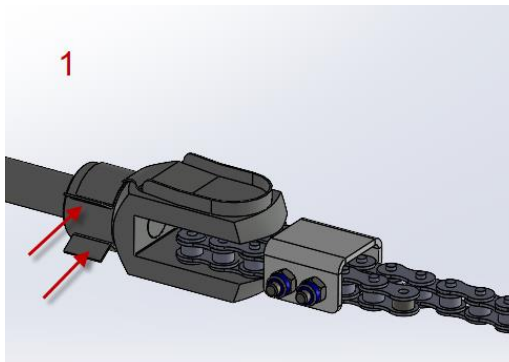

5. When gaspring have no longer connection with screw, remove chain from the gaspring. (It is possible to open arms now to have better access to the chain and gaspring)

6. Use new gaspring and attach it to the chain.

7. When gaspring is connected to the

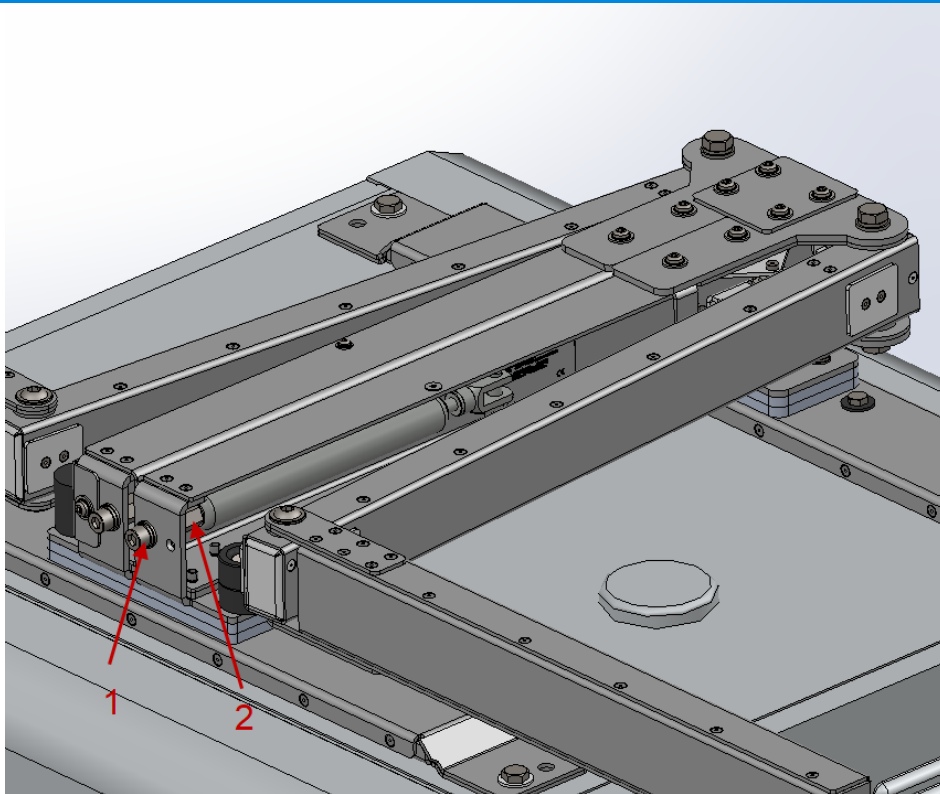

chain, close the arm like shown in picture on the left side and reinstall gasspring to the CMS using screw M10 and washers with torque 40Nm. (remember about wrench 17 to block rotation of the gasspring with chain).

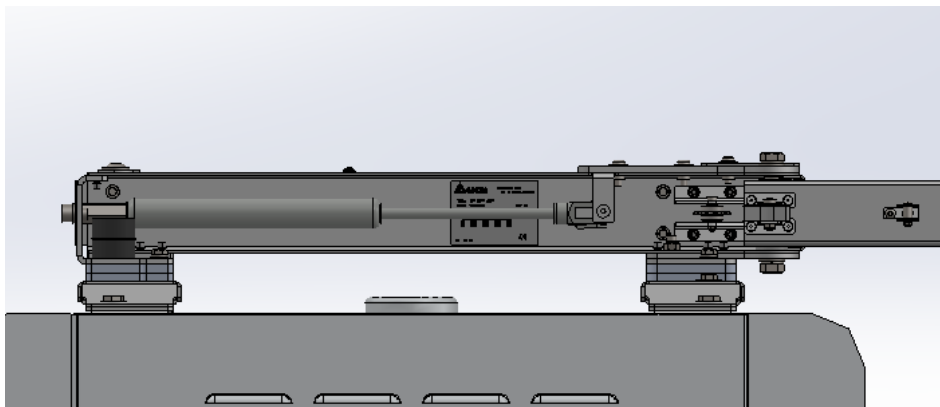

8. Open arms of CMS (second operator should hold ARM 2 all the time to prevent accidents), assembly cover ARM 1 using screw with washers M4 with torque 3Nm and M6 with torque 9Nm. When putting cover while bumper in assembled to the CMS is impossible, remove the bumper with screw M10 and then reinstall it after cover instalation.

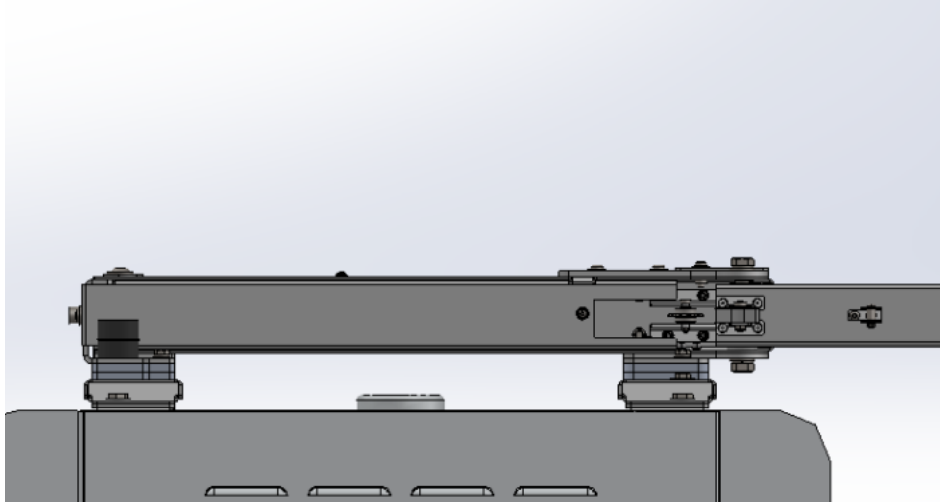

9. Back to the **chapter 8 – CMS Assembly instruction** to the point 8,9,10 to perform clamp assembly.

12 Restrictions and guidelines for use

12.1 Restrictions

- ▶ Do not allow the CM to twist, tangle or crush the charger cables. Twisting the cables can lead to insulation damage, which in turn can lead to the risk of an electrical accident.
- ▶ Avoid installing the system near heat sources that may affect the internal temperature of the system. High temperature can affect system performance and security.
- ▶ Do not hang up on the CM structure as this may damage it and cause it to malfunction and additional damage may be caused to the charger.
- ▶ Do not pull the wires in order to damage the structure, the cable may break from the holder or damage the structure.

12.2 Guidelines

- ▶ Mount the CM by following the steps in the instructions
- ▶ At each periodic inspection of the charger, check the status of the system to make sure it is working properly and without damage. Repair immediately if there is any damage.
- ▶ Use the system only for its intended purpose Do not use it for other purposes that may damage it.
- ▶ After the car charging process is completed, the Gun with the cable should be put back in the designated place,



Delta-Servicekontakte

EVCS.Service@deltaww.com

Delta Electronics (Netherlands) BV

Zandsteen 15, 2132 MZ Hoofddorp,

Tel.: +31 20 655-0900

Evcs.emea@deltaww.com

Emobility.delta-emea.com

Über Delta

Delta wurde 1971 gegründet und ist ein weltweit führender Anbieter von Lösungen für das Energie- und Wärmemanagement. Wir wollen innovative, saubere und energieeffiziente Lösungen für eine bessere Zukunft bereitstellen und sind in unter anderem in den Bereichen Leistungselektronik, Energiemanagement und Smart Green Life tätig. Delta verfügt über Vertriebsniederlassungen, Fertigungsstätten sowie Forschungs- und Entwicklungszentren auf der ganzen Welt. Im Jahr 2014 rangierte Delta auf der höchsten Klassifizierungsebene A des Climate Performance Leadership Index des Carbon Disclosure Project (CDP). Seit 2011 ist Delta Teil des Dow Jones Sustainability Indices (DJSI) World Index.